

EVACHIP-42

DESCRIPTION The μPD555 is a system evaluation chip designed to support both hardware and software debugging of the μCOM-42 (μPD548) one-chip microcomputer system.

The μPD555 and the μPD548 have the same functionality in all aspects except that the μPD555 does not contain a read only memory, but provides addressing capability to external memory and HOLD function for step-by-step operation.

FEATURES

- 4-Bit Parallel Processor
- Powerful 72 Instruction Set Including Decimal/Binary Arithmetic Operations
- 10 μs Instruction Cycle Time
- Addressing Capability up to 1920 Words by 10-Bits of External Program Memory
- 96 Words by 4-Bit Data Memory On Chip
- 4-Level Subroutines
- Two Interrupt Input Lines (IA and IB)
- HOLD Capability
- A Variety of Input/Output Ports –
 - 10 Discrete Output Ports (F₉-F₀)
 - Two 8-Bit Output Ports (U₇-U₀, R₇-R₀)
 - 4-Bit Input Port (K₃-K₀)
 - 4-Bit Input/Output Port (S₃-S₀)
 - I/O Level Compatible with μPD5101
 - 1-Bit Test Input Line
- P-Channel MOS
- Open Drain Output
- Single Power Supply: -10V
- Available in a 64 Pin Ceramic Dual-in-Line Package

PIN CONFIGURATION

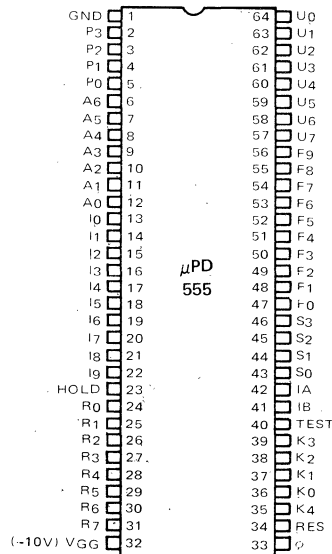

PIN NAMES

P ₀ – P ₃	Page Output
A ₀ – A ₆	Address Output
I ₀ – I ₉	Instruction Input
HOLD	HOLD Input
R ₀ – R ₇	Output Port R
φ	Clock Input
RES	Reset Input
K ₄	K ₄ Test Input Line
K ₀ – K ₃	K Input Port
TEST	IC Test Input
IA, IB	Interrupt Input
S ₀ – S ₃	Input/Output Port S
F ₀ – F ₉	Output Port F
U ₀ – U ₇	Output Port U

6

μPD555

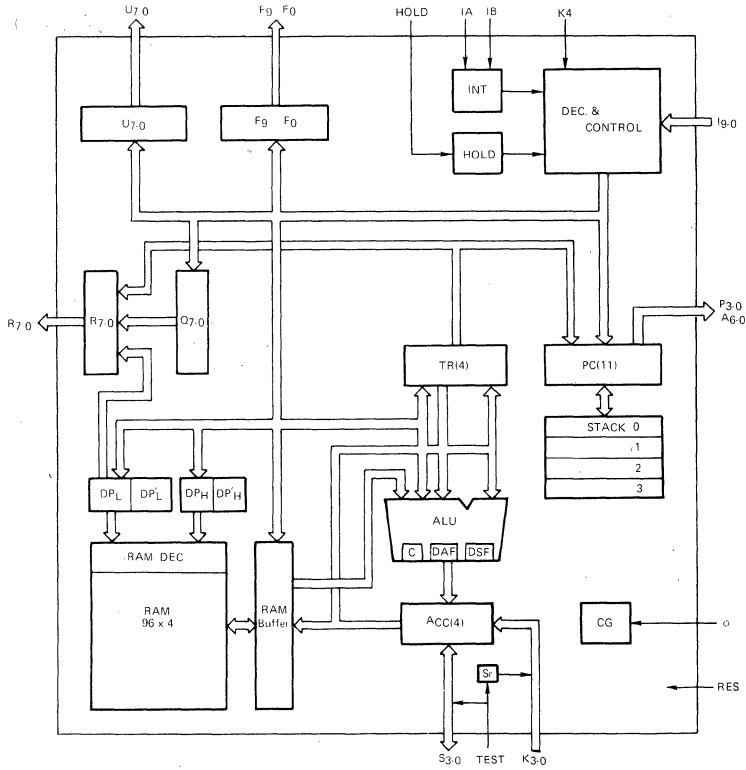

BLOCK DIAGRAM

Operating Temperature	-10°C to +70°C
Storage Temperature	-40°C to +125°C
Supply Voltage V _{GG}	-15 to +0.3 Volts
All Input Voltages	-20 to +0.3 Volts
All Output Voltages	-20 to +0.3 Volts

ABSOLUTE MAXIMUM RATINGS*

COMMENT: Stress above those listed under "Absolute Maximum Ratings" may cause permanent damage to the device. This is a stress rating only and functional operation of the device at these or any other conditions above those indicated in the operational sections of this specification is not implied. Exposure to absolute maximum rating conditions for extended periods may affect device reliability.

*T_a = 25°C

T_a = 25°C

CAPACITANCE

PARAMETER	SYMBOL	LIMITS			UNIT	TEST CONDITIONS
		MIN	TYP	MAX		
Input Capacitance	C _I			15	pf	f = 1 MHz
Output Capacitance	C _O			15	pf	
Input/Output Capacitance	C _{IO}			15	pf	

μPD555

DC CHARACTERISTICS $T_a = -10^\circ\text{C}$ to $+70^\circ\text{C}$; $V_{GG} = -10\text{V} \pm 10\%$, unless otherwise noted.

PARAMETER	SYMBOL	LIMITS			UNIT	TEST CONDITIONS
		MIN	TYP	MAX		
High Level Input Voltage	V_{IH}	0		-2.0	V	
Low Level Input Voltage	V_{IL1}	-4.3			V	S, ϕ , I ₉₋₀
	V_{IL2}	-7.0			V	Except S, ϕ , I ₉₋₀
High Level Input Leakage Current	I_{LIH}			+10	μA	$V_I = -1\text{V}$
Low Level Input Leakage Current	I_{LIL}			-10	μA	$V_I = -11\text{V}$
High Level Output Current	I_{OH}	-1.0			mA	$V_O = -1\text{V}$, except S port
Low Level Output Leakage Current	I_{LOL1}			-30	μA	$V_O = -11\text{V}$, except S port
High Level Output Voltage	V_{OH}			-1.75	V	$I_{OH} = -100\ \mu\text{A}$, S port
Low Level Output Leakage Current	I_{LOL2}			-10	μA	$V_O = -5\text{V}$, S port
Power Supply Current	I_{GG}		-30	-60	mA	

AC CHARACTERISTICS $T_a = -10^\circ\text{C}$ to $+70^\circ\text{C}$, $V_{GG} = -10\text{V} \pm 10\%$, unless otherwise noted.

PARAMETER	SYMBOL	LIMITS			UNIT	TEST CONDITIONS
		MIN	TYP	MAX		
Clock Frequency	f_ϕ	100		200	KHz	
Clock Pulse Width	$t_{\phi w}$	2.25				
Clock Rise and Fall Times	t_r, t_f			0.5	μs	
Input Setup Time from Output	t_{IS}			2.5	μs	$C_L = 100\ \text{pF}$, $R_L = 5.1\ \text{K}\Omega$

6

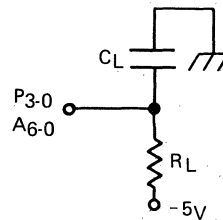

LOAD CIRCUIT

μPD555

TIMING WAVEFORM

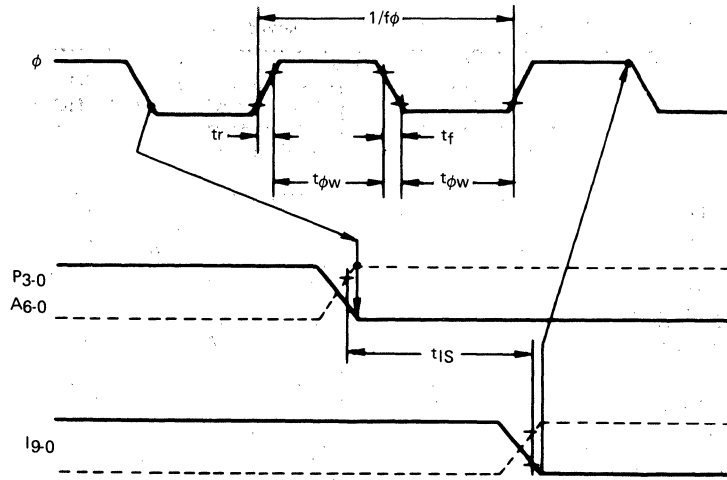

PACKAGE OUTLINE μPD555D

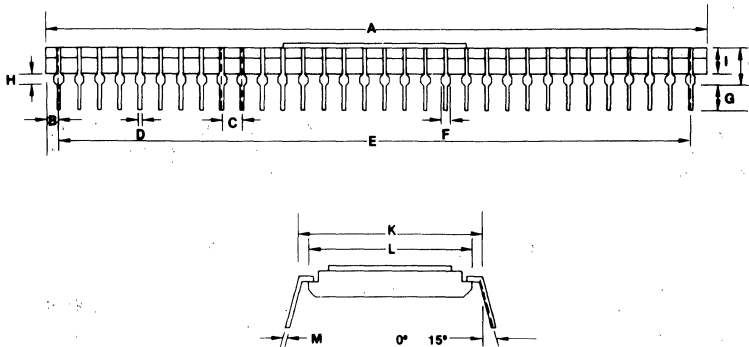

ITEM	MILLIMETERS	INCHES
A	82.0 MAX	3.23 MAX
B	1.6	0.063
C	2.54	0.1
D	0.43 ± 0.1	0.017 ± 0.004
E	78.8	3.1
F	1.27	0.05
G	3.2 MIN	0.13 MIN
H	1.3 MIN	0.05 MIN
I	3.9	0.154
J	5.2 MAX	0.205 MAX
K	22.96	0.904
L	20.3	0.8
M	0.3 ± 0.1	0.012 ± 0.004