

CONVERGENCE
ENHANCED MULTIMEDIA
MULTIMEDIA
VALUE

# MSM6150™ Chipset Solution

## Maximize market share with a power-efficient, single-chipset solution for high-intensity wireless multimedia

The QUALCOMM Enhanced Multimedia Platform of chipsets takes the true multimedia handset from concept to reality. These chipsets make a leap in processing power to deliver the quality of video, graphics and audio that will amaze users today and define the multimedia experience for years to come. This enormous performance gain is backed by power efficiency and chip design that make the most sophisticated wireless multimedia both possible and profitable.

By deploying a single-chip design, this platform enables sleek, sophisticated media devices with large, high-resolution screens that deliver rich multimedia features such as 4.0 megapixel camera compability, video-on-demand, 3D gaming and video telephony. Picture quality is so crisp, games are so realistic and video streams are so fast that users are compelled to seek out more and more exciting content, driving demand for airtime and additional services.

The QUALCOMM Enhanced Multimedia Platform is the industry's best solution for extending the capabilities of true wireless multimedia in 3G. It has a chipset solution for all major air interfaces and the power, speed and efficiency to run high-end multimedia that will revolutionize what people can do on a handset.



THE QUALCOMM ENHANCED MULTIMEDIA PLATFORM OF CHIPSETS TAKES THE TRUE MULTIMEDIA HANDSET FROM CONCEPT TO REALITY.



### PERFORMANCE

Integrated architecture ensures designs that minimize development time and expense and accelerate return on investment

- Air interfaces supported:
  - CDMA2000® 1X (Revision 0 and A)
- High-performance ARM926EJ-S™ microprocessor core with memory management unit (MMU)
- Two QDSP4000™ high-performance digital signal processors (DSP)
- 225 MHz ARM9™ Jazelle™ Java® hardware acceleration for faster Java-based games and other applets
- Enhanced memory support for NAND, burst mode NOR, SDRAM and burst mode PSRAM
- Advanced 409-pin 0.5 mm pitch CSP package (14 mm x 14 mm)
- Support for popular third-party operating systems
- Open BREWapi™ for developing BREW® and Java® applications

# MSM6150™ Chipset Solution

The Mobile Station Modem™ (MSM™) MSM6150™ solution for CDMA2000 1X networks powers the blazing-fast speeds required to run the high-impact, multimedia applications that maximize profitability and drive revenue. Deliver high resolution, data-enabled devices designed for demanding consumers with the MSM6150 chipset.

## GRAPHICS

### Game quality rivaling home consoles

- Advanced 2D/3D graphics support with up to 100,000 3D triangles per second, and 7 million depth-tested, textured and 7 million depth-tested, shaded 3D pixels per second fill rate
- Q3Dimension™ for OpenGL® ES-compliant 3D graphics
- Dedicated hardware support for 3D rendering
- Supported by leading third-party game titles
- Up to Quarter Video Graphics Array (QVGA) resolution

## VIDEO

### Television-like clarity and camcorder-like recording

#### Qtv™:

- High-performance video player powers streaming video- and audio-on-demand plus video messaging at 30 fps QVGA
- Supports MPEG-4, H.263 and H.264 video codecs and QCELP®, AMR-NB, EVRC, AAC and aacPlus™ audio codecs

#### Qcamcorder™:

- A real-time wireless video recording solution that captures movies at 15 fps QVGA
- Supports MPEG-4, H.263 and H.264 video codecs and QCELP®, AMR-NB, EVRC and AAC audio codecs

## POSITION LOCATION

### Highly accurate positioning for location-based services (LBS)

- gpsOne® position-location hybrid A-GPS solution
- Support for commercially deployed consumer LBS applications
- High-availability, all-terrain solution
- Support for MS-Assisted, MS-Based and Standalone GPS, which enables off-network support

## CONNECTIVITY

### Connection with indispensable consumer electronics

- Supports QUALCOMM's high-speed serial interconnection technology, Mobile Digital Display Interface (MDDI), for increased reliability in clamshell phones
- Integrated Bluetooth® 1.2 baseband processor for wireless connectivity to peripherals
- Universal serial bus (USB) on-the-go (OTG) functionality
- SecureMSM™ v1.0: supports subsidy protection and device-identifier integrity, including ESN

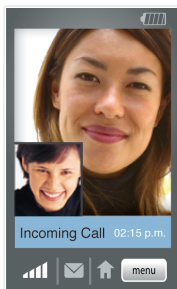
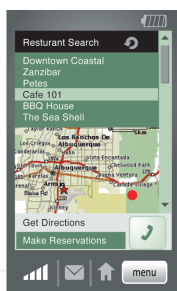
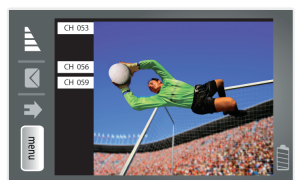

## IMAGING

### Integrated digital-still camera interface

- Qcamera™ with 30 fps QVGA viewfinder resolution
- Support for up to 4.0 megapixel camera sensors with a flexible, integrated interface to CCD and CMOS sensors
- Integrated JPEG for camera-based applications
- Full image processing capabilities, including color correction, crop, resize, rotation, image blurring and sharpening, image overlay, picture frame support and visual noise reduction

## AUDIO

### Audio that's on par with popular portable music players

- PureVoice Audio AGC™ (automatic gain control) for better calls, especially under noisy conditions
- Digital audio support for MP3, AAC, aacPlus™ and Enhanced aacPlus
- CMX™ for customized ringtones, screensavers and greeting cards:
  - MIDI-based voice (up to 72 polyphony)
  - Time-synchronization capabilities for MIDI-based content
  - Playback support for compact MIDI, level one and two compliant general MIDI, SMAF™ (audio only), SP-MIDI and XMF/DLS
- QConcert™ surround sound and QAudioFX™ enhanced gaming audio
- Integrated stereo (44.1 kHz and 48 kHz) wideband codec capable of CD-quality playback
- QUALCOMM Audio Post Processor (QAPP)

## OPTIMIZED RF AND PMIC SOLUTIONS

QUALCOMM's radioOne® zero-IF radio frequency and powerOne™ power management solutions are optimized for our MSM chipsets for high-efficiency, price-competitive wireless devices. Expect a higher return on investment with our integrated solution — fewer discrete parts means lower development costs, lower BOM costs and ultimately lower handset costs. With our innovative RF CMOS processing technology on select chipsets and lead-free packaging solutions, handset manufacturers can be confident that wireless devices based on our complete solutions will be power efficient, dependable and cost competitive.

## MSM6150 | AVAILABLE RF & PM CHIPSET COMBINATIONS

RF Chipset Configurations	RFL6000™ RFR6000™ RFT6100™	RFR6125™ RFT6120™	RFL6000™(2) RFR6000™(2) RFT6100™	RFR6125™ RFR6120™ RFT6120™	RFR6500™ RFT6150™	RFR6525™ RFT6150™
Power Management IC	PM6650™	PM6650™	PM6650™	PM6650™	PM6650™	PM6650™
CDMA2000	450 MHz					
	CELL 850 MHz	■	■	■	■	■
	JCDMA 800 MHz	■	■	■	■	■
	KPCS 1800 MHz	■		■	■	
	PCS 1900 MHz	■		■	■	
	IMT 2100 MHz	■		■		■
GSM	900 / 1800 MHz					
GPS	SH = Shared SI = Simultaneous	SH	SH	SH	SH	SI
Receive Diversity			■	■	■	■

# MSM6150™ Chipset Solution

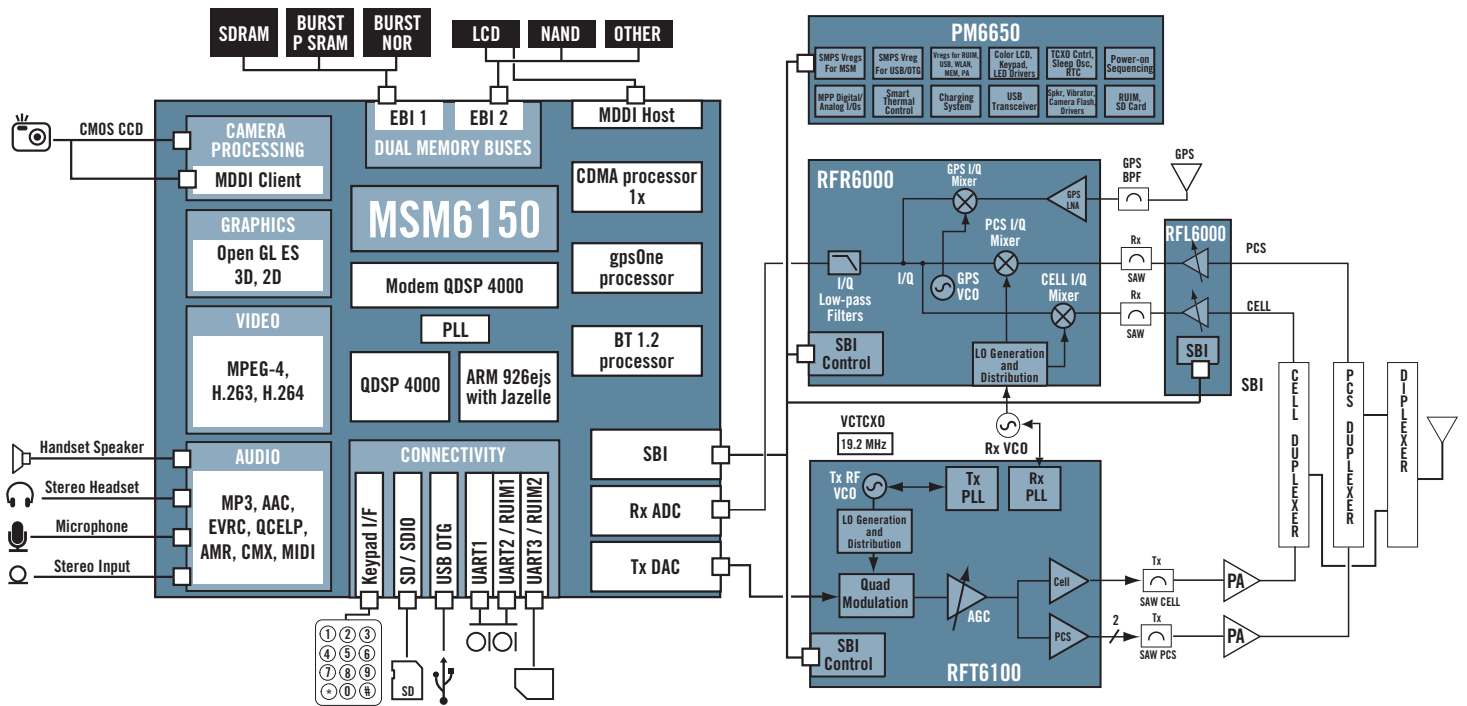

Go Online

CHIPSET COMPARISON ONLINE TOOL

Please visit [www.cdmatech.com/enhancedplatform](http://www.cdmatech.com/enhancedplatform) to view the chipset comparison tool that details specific chipset features.

© 2005 QUALCOMM Incorporated. All rights reserved. QUALCOMM, gpsOne, QCELP, BREW and radioOne are registered trademarks of QUALCOMM Incorporated. Mobile Station Modem, MSM, MSM6150, QDSP4000, Q3Dimension, Qcamera, CMX, Qsynth, Qcamcorder, QConcert, QAudioFX, Qtv, SecureMSM, RFL6000, RFR6000, RFR6125, RFR6120, RFR6500, RFR6525, RFT6100, RF16120, RFT6150, PM6650 and powerOne are trademarks of QUALCOMM Incorporated. Microsoft and Windows Media are registered trademarks or trademarks of Microsoft Corporation in the U.S. and/or other countries. RealNetworks and RealPlayer are registered trademarks or trademarks of RealNetworks, Inc. OpenGL is a registered trademark of Khronos Group. Java is a registered trademark of Sun Microsystems, Inc., in the United States and other countries. ARM9, Jazelle and ARM926EJ-S are trademarks or registered trademarks of ARM Limited. Synthetic music Mobile Application Format and SMAF are trademarks of Yamaha Corporation of America. aacPlus is a trademark of Coding Technologies. Open Mobile Alliance is a trademark of the Open Mobile Alliance Ltd. Bluetooth and the Bluetooth logos are trademarks owned by Bluetooth SIG, Inc., USA. CDMA2000 is a registered certification mark of the Telecommunications Industry Association. Used under license. All other trademarks and service marks are the property of their respective owner. Data subject to change.

MSM6150\_5/2005 Rev. B